

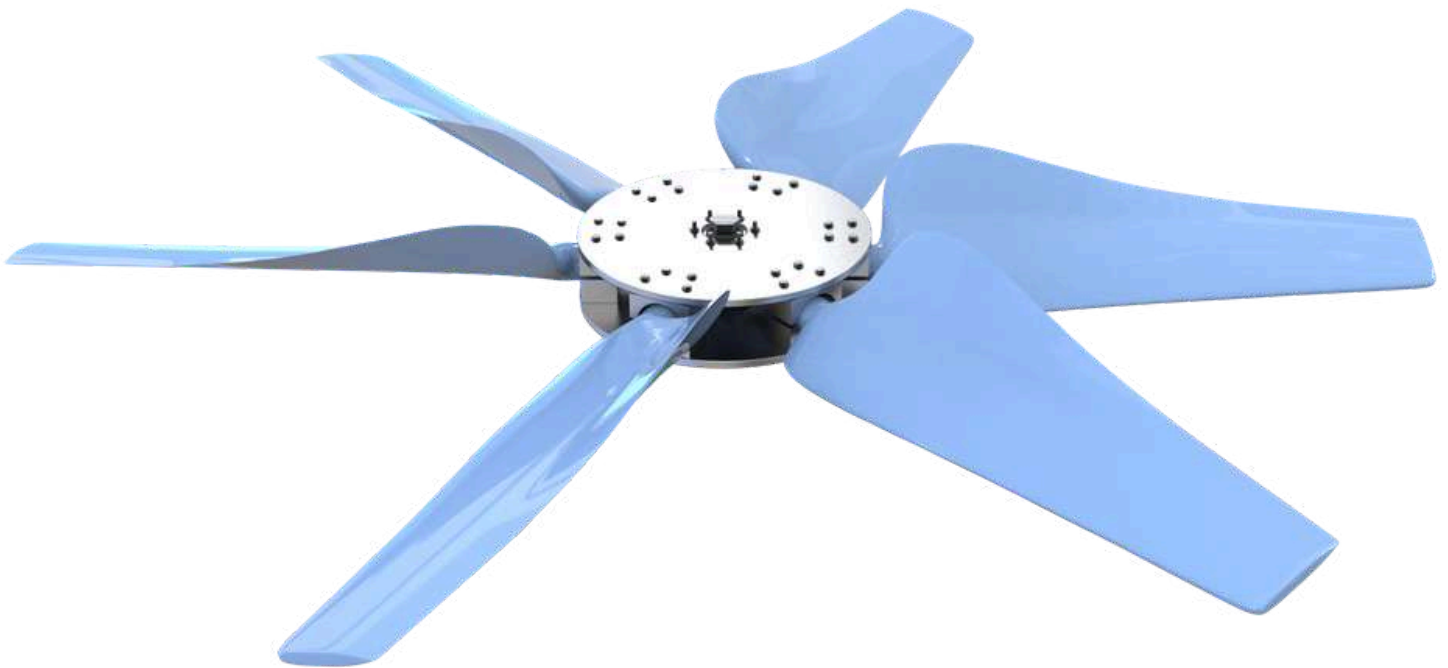

Energy Conservation with PAC Hyperfans



INTRODUCTION:

The disruption of energy sources and resulting tenfold increase in petroleum prices has placed Energy Efficiency and Conservation near the top of plant and institutional planning. Operators of **Cooling Towers / Industrial Ventilation and Exhaust / Radiator Cooling / Air Cooled Heat Exchangers / Humidifiers / Mine Ventilation / Withering Troughs** are constantly searching for innovative methods and equipment to lower total heat transfer cost and maintain constant process temperatures. One piece of equipment, which obviously meets the goal, is Axial Flow FRP Fans.

The reason Axial Flow FRP Fans are an obvious choice are as follows:

- Low initial cost
- Low horsepower requirement
- Low noise without extra cost
- Low maintenance cost

PAC FRP fan designs have been under constant improvement.

The fan efficiency and pressure capabilities have all advanced significantly over the years. PAC FRP Fans operate at 82-86 % mechanical efficiency as compared to 50-60 % efficiencies common with most of aluminum fans.

Modern Fibre Glass (FRP) fans normally enjoy quite a long service life. PAC FRP fan designs incorporate aerofoil design and a lesser number of blades per fan for efficiency. For each fan there is a "design point" which is established by specific airflow, total pressure, air density, fan speed and aerofoil selection. Starting with this data, it is possible to determine the one platform and twist distribution which will accomplish the required work with minimum horsepower.

Maximum fan performance means more than just maximum airflow for minimum horsepower, although that may be its most important parameter. Maximum fan performance also means that the fan achieves its expected service life with no problems. It could also mean that the fan meets its noise limitation specifications, if there is one, and that its vibration is low or meets a given limit.

Following is a discussion of how some major factors such as the original selection, installation and operating environment also have a significant impact on whether maximum fan performance is achieved.

SELECTION OF THE FAN:

There are many fan combinations that will meet any given duty or operating requirements. The goal is to find the best one. This requires optimizing cost, horsepower and sound requirements. Horsepower is determined by a required airflow (m³/sec. or CFM), the system resistance to that airflow (called Static Pressure) and the fan efficiency.

FAN EFFICIENCY:

There are two kinds of fan efficiencies, Static and Total. It is easy to understand that the fan must work (move air) against the system resistance, which is called Static Pressure and is measured in Pascal (N/m²) or inches of water column (in - H₂O). The other work the fan must do is to collect air from 360° around its inlet and draw it through the fan. This work is also measured in Pascal (N/m²) or inches of water column (in- H₂O) and is called Velocity Pressure. Velocity Pressure is not useful work and is called Parasitic Loss. The total work the fan has to do is against the Static Pressure plus Velocity Pressure. Not surprisingly this sum is called Total Pressure and the measure of how well the fan performs is called its Total Efficiency. If we consider only the useful work (Static Pressure) we consider Static Efficiency. In either case the horsepower required includes the parasitic work required to collect the air into the fan inlet. This brings up the question which is most important to consider: Total Efficiency or Static Efficiency.

Efficiency is calculated as below:

Total Efficiency	= $\frac{\text{Total Pressure (Pa)} \times \text{Air Flow (m}^3/\text{sec.)}}{1000 \times \text{Fan Shaft Power (kW)}}$
Static Efficiency	= $\frac{\text{Static Pressure (Pa)} \times \text{Air Flow (M}^3/\text{s)}}{1000 \times \text{Fan Shaft Power (kW)}}$

If considered their relationship by looking at a performance curve of one of the most popular fan type:

First consider how Total Efficiency and Static Efficiency vary along a pitch line. This pitch line describes the CFM (cubic feet per minute) and Static Pressure response of a given fan at a given density and speed.

Figure 1. Shows the specific pitch performance by one fan manufacturer at five different random operating points. Note that Static Pressure is always zero at the “Free Flow” point of the curve. It should be because at that point Total Pressure equals Velocity Pressure and Static Pressure is zero.

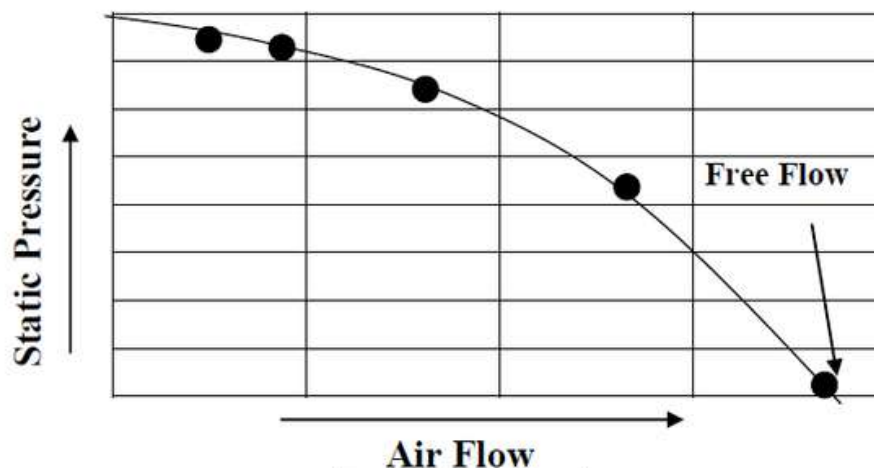
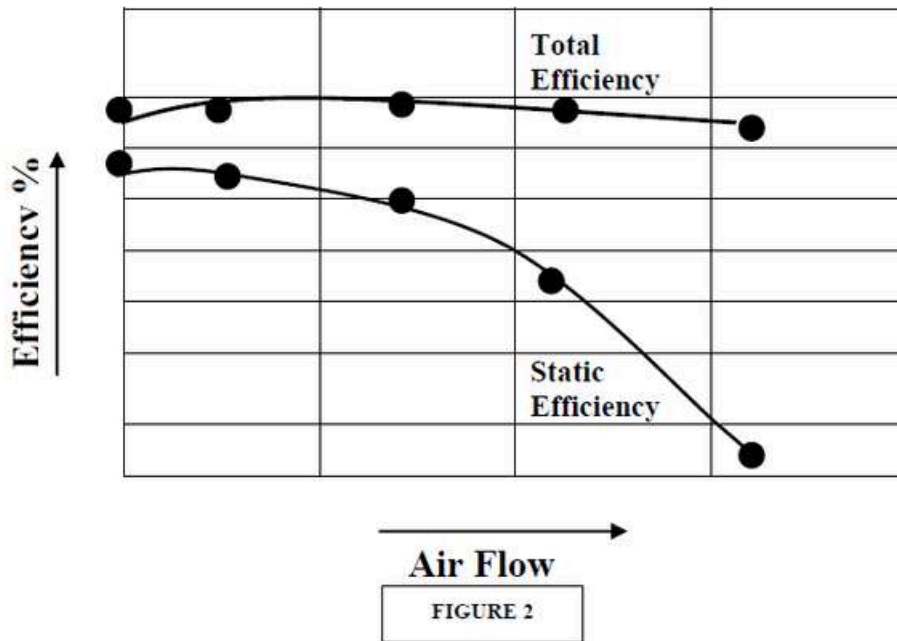

FIGURE 1

Figure 2 shows how Total and Static Efficiency vary as air flow increases



Note that Total Efficiency remains relatively constant, but Static Efficiency is maximum at low flow, high static pressure region. Note this optimum efficiency occurs just before fan “stall” even though the stall point may not be shown on the curve. Every axial flow fan operates on these same principles. Assume you have the Static Pressure versus CFM response for your optimum system resistance. There are many fan combinations of blade and speed variations where the fan output, in terms of static pressure and flow, meets the exact requirement of your “system”. If the duty point has already been established, what are the options to maximize performance? The fan speed and number of blades per fan can be varied, for instance.

The most important point is that varying tip speed for a specific duty typically does not have a major effect on power for the same number of blades since the fan duty point is the same for all speeds. The number of blades typically increases as we slow down to lower tip speed and decreases as we speed up. For a specific duty point, as blade count go up, efficiency generally goes down and power required goes up on most fans.

Optimizing fan speed can minimize this decrease in efficiency.

Figure 3 shows a dramatic change in required power at various diameters. This is because the operating point moves towards maximum static efficiency as the diameter increases, even though the Static Pressure and flow required is the same for all cases. SE and TE on the curve represent Static Efficiency and Total Efficiency at each point.

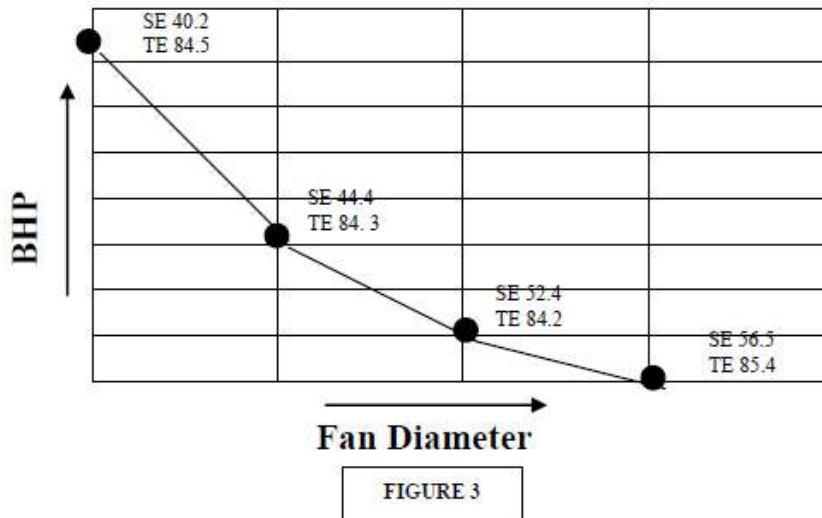

There will also be a minor difference in horsepower as a function of pitch angle and speed in the same fan. This is because some angles are more efficient than others. This is the case for any fan.

Some conclusions that can be drawn for a given fan:

- Static Efficiency, not Total Efficiency, indicates useful work.
- Static Efficiency peaks at high pressure and low flow for each blade pitch line.
- Efficiency varies continually along the pitch line as CFM and Actual Static Pressure changes.
- The Efficiency you achieve is primarily a function of the fan selection and the operating point, which is a function of the system resistance.
- Varying the fan speed, if the number of blades and the specific duty remains the same, does not have a major impact on reducing horsepower.
- Using the largest diameter fan possible maximizes Static Efficiency and minimizes Velocity Pressure for a fixed duty. Optimizing fan speed and pitch angle for the diameter chosen can make further improvement.

FACTORS AFFECTING FAN PERFORMANCE: AEROFOIL DESIGN:

A fan blade induces air flow by virtue of the blade surface imparting dynamic energy to the air, the more efficient the blade aerofoil, the greater the air flow. The measure of how efficiently the blade is able to move air can be determined by the blade's aerofoil Coefficient of Lift (C_l); the higher the C_l , the more efficient the blade. The resistance the blade offers to the air flow is determined by the Coefficient of Drag (C_d); the higher the C_d , the less efficient the blade.

A simple way of characterizing the overall efficiency of the blade is to plot (C_l) and (C_d) values against various angles of attack. The aerofoil with the greatest C_l / C_d value would be the most efficient.

A blade profile with a greater twist and camber allows for more efficiency and uniform flow. Parag FRP fan blades manufactured by a unique molding process, incorporate greater twist, camber and wider chord widths that are difficult to achieve with conventional metallic fans.

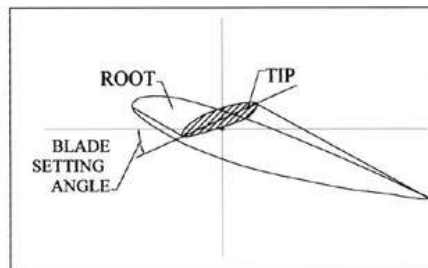

FIGURE 4

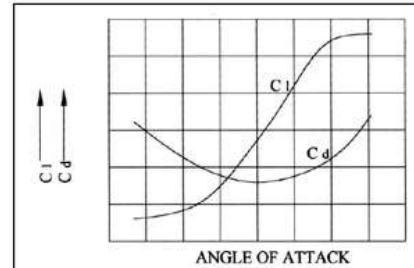

FIGURE 5

STRUCTURAL DESIGN OF A FAN BLADE:

During the course of operation, a fan is subjected to great aerodynamic and mechanical loads, and therefore must be designed to withstand such forces for the duration of its life. Due to the precise integrated fiber matrix used in Parag FRP fans, higher fatigue strength is achieved as compared to conventional aluminum fans.

FAN SPEED / TIP SPEED:

Noise emitted by the fan is a function of tip speed to the 6th power (approx.). Thus a small reduction in tip speed has considerable effect on noise level.

To optimize the fan performance and noise level, operating points can be worked out at various speeds, by applying the fan laws i.e.

- (a) Airflow varies directly with the speed N
- (b) Total pressure varies as N^2 and
- (c) Fan power varies as N^3 .

The final operating speed can be selected by a compromise between the best efficiency point speed and available motor speeds. Many fans have critical speed ranges. The fan operating speed should not fall within this critical range.

INLET SHAPE & OBSTACLES:

The flow pattern in which the air flows through the inlet to the fan tip is of paramount importance. As the air is induced out of the plenum chamber beneath the fan, it tends to follow very predictable streamlines into the fan casing. As the air moves into the casing, a vena contracta develops. The best-suited shape of the fan casing as well as the optimum height of the fan in casing is actually based on this Vena contracta.

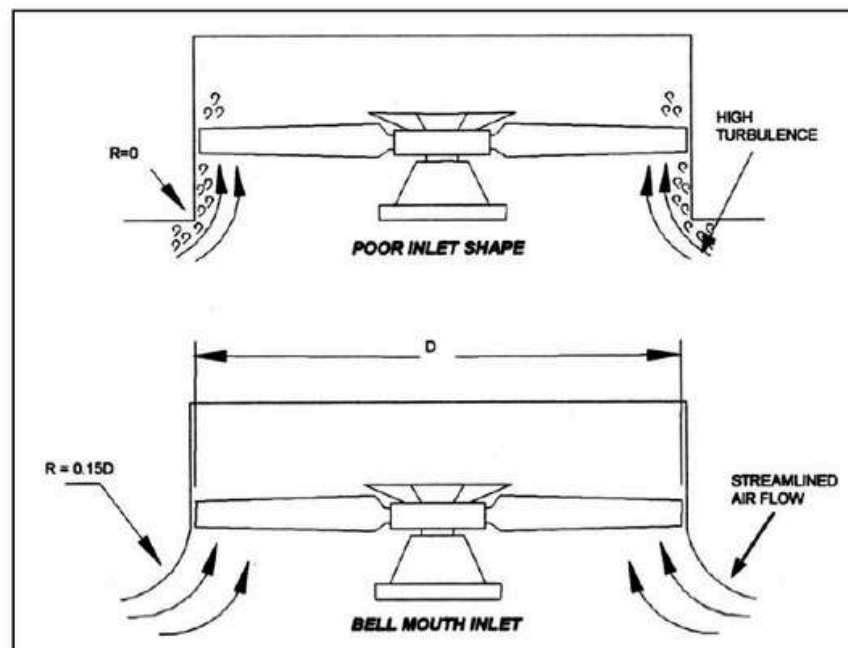

FIGURE 6

The straight-sided inlet shape would definitely deteriorate the fan performance due to the following:

- (a) The fan blade tips are operating outside the vena contracta in a region of low airflow.
- (b) The area between the casing wall and the vena contracta develops high turbulence, which further increases the pressure loss and thus reduces fan efficiency.
- (c) If the fan is located low in the casing, then the air approaching the blades attacks at an angle, causing further efficiency degradation, as the blades have to perform the additional work of turning the air.
- (d) In general, the best operating results are obtained when the airflow has a smooth entry to the fan. This can be best achieved by providing an inlet bell mouth shape. The bell mouth shape reduces the turbulence as the air enters the fan, with uniform velocity. This shape also reduces the noise turbulence. The optimum bell radius is $R/D = 0.15$ where R is the radius of the bell and D is the fan diameter.

EFFECT OF OBSTACLES PRESENT IN THE AIR FLOW OF THE FAN:

Obstacles located in either the front or the back of a fan may affect the efficiency due to the turbulence caused by the interference in the air flow. Such interference in the air flow also tends to increase the noise level.

Obstacles in the path of the air flow will induce a higher velocity pressure. This is due to the reduction of 'Fan Net Free Cross Sectional Area' that the air is flowing through. The ultimate effect is a loss in the static efficiency of the fan.

Although in an actual situation, it is virtually impossible to have completely obstacle free air flow path, an optimum compromise can be achieved by reducing the number of obstacles and streamlining the required structural members.

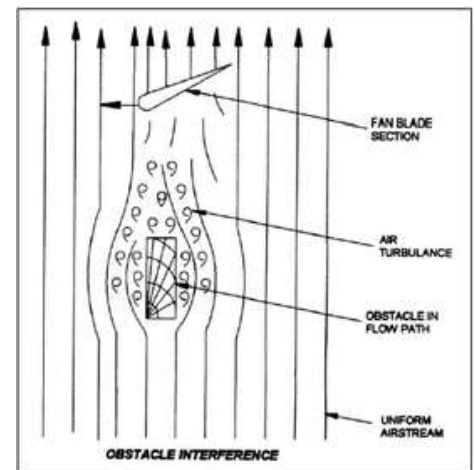

FIGURE 7

BLADE PITCH ANGLE:

Varying the blade pitch angle has a proportional effect on the static pressure, increasing the pitch angle results in a higher static pressure and vice versa. For any specified duty, the applicable fan will have an optimum pitch angle setting pertaining to its maximum achievable efficiency. In general, it is advised that all the blade tip angles should be set at least two degrees less than the maximum permissible pitch angle to avoid a stall condition. Further, it is advisable that all the blades are set at the same pitch angle to prevent excessive noise and vibration.

TIP CLEARANCE:

The clearance between the tip of the blade and the fan casing influences the fan performance. Large tip clearances allow the shedding of a vortex from the upper surface of the blade back to the low-pressure area beneath the fan; this produces lowered airflow rates and reduced fan efficiency. The smaller the fan diameter the greater the sensitivity to changes in tip clearance since a larger portion of the smaller blade is being influenced by the tip clearance.

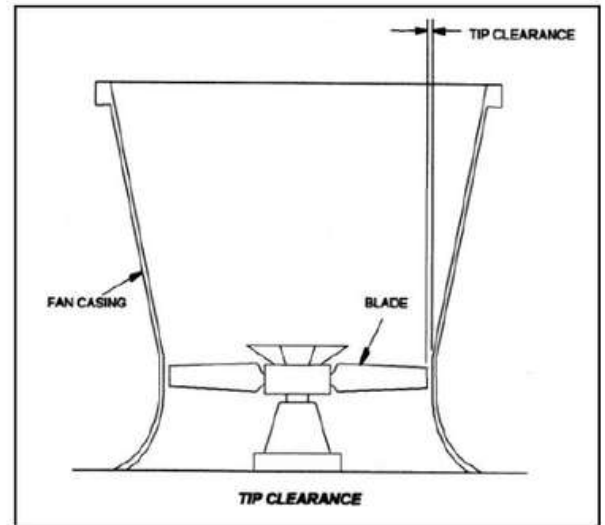

FIGURE 8

ALTITUDE & TEMPERATURE:

With varying atmospheric conditions, the air density value changes. This change directly affects the pressure and power characteristics of a fan. Pressure and power vary proportionally to the air density; however, the air flow will remain the same.

VELOCITY RECOVERY CONE:

The purpose of a velocity recovery cone is to reduce the exit velocity pressure and thereby convert the velocity pressure losses into useful pressure work. It is advisable to use a velocity recovery cone in order to reduce the power consumption when the operating velocity pressure is more than 5 mm WG (0.2 in WG). The efficiency of the velocity recovery cone is normally 60% to 80%, depending on the length of the cone to fan diameter ratio.

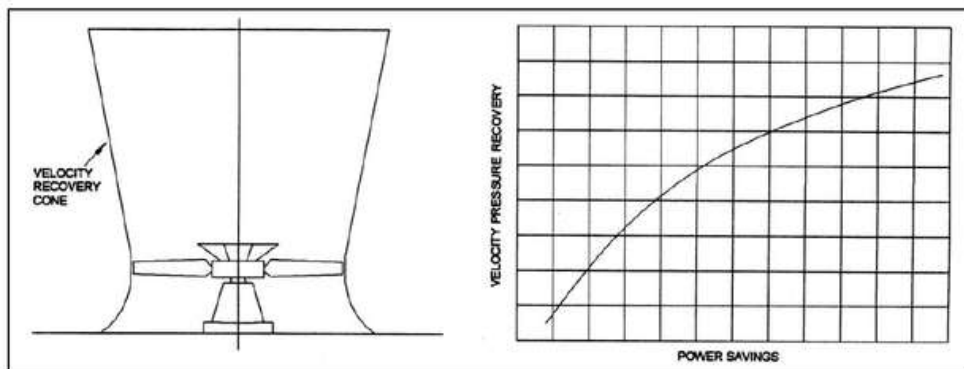

FIGURE 9

BLADE LEVELING:

It is important that all the blades are leveled on the same plane. Difference in blade levels will result in increased fan vibration and noise. The recommended level variation between any given blade on a fan of up to 20 feet in diameter should not exceed 15 mm, and 25 mm for fans larger than 20 feet diameter.

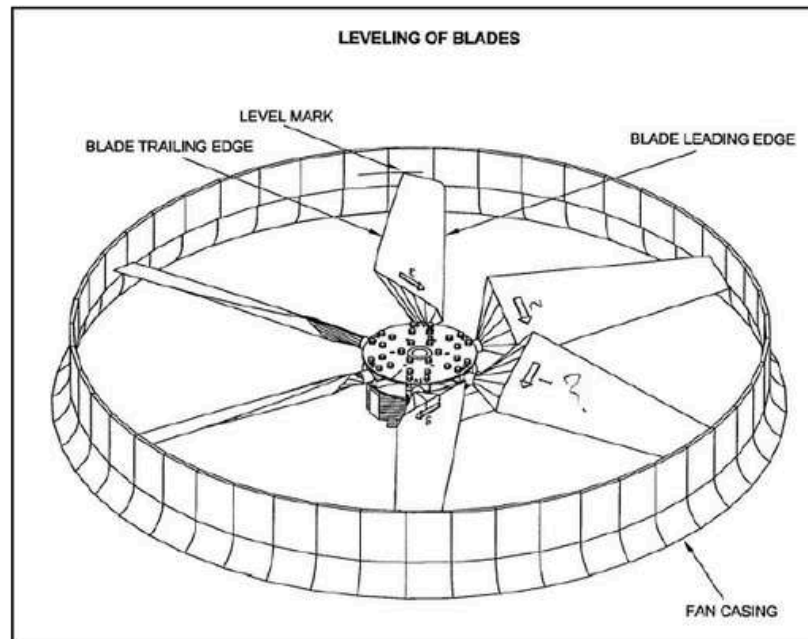

FIGURE 10

SEAL DISC:

During the fan operation, regions near the hub have a reverse air flow. The overall result is a reduction in air flow and thus loss of efficiency. To minimize the reverse air flow, a seal disc may be mounted on the discharge side of the hub.

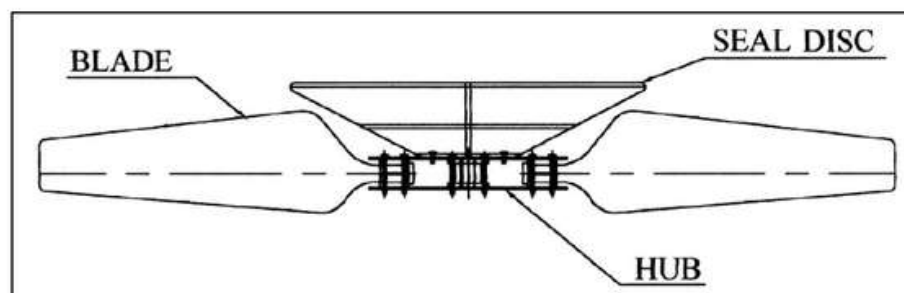

FIGURE 11

ENERGY SAVING WITH PAC Hyperfans BY REPLACING EXISTING CONVENTIONAL ALUMINUM / FRP / GRP FANS

In case of Cooling Towers / Radiator Cooling / Air Cooled Heat Exchangers / Mine Ventilation / Humidification plants / Withering Troughs in Tea Industries the purpose of a fan is to move a specified quantity of air through the system. While doing so the fan has to overcome the system resistance which is defined as the pressure loss. The product of airflow & the pressure loss is air power developed / work done by the fan; this may also be termed as Fan output.

To obtain the desired output from the fan, an input in the form of electrical energy is to be provided, which is equal to $\frac{\sqrt{3} \times V \times I \times \text{Cos}\Phi}{1000}$ kW. Where as V = Voltage, I = Current (Amps)
CosΦ = Power Factor

It is thus obvious that a fan with a higher efficiency will require less input power. The fan efficiency in turn

is greatly dependent on the profile of the blade. An aerodynamic profile with the optimum twist, taper & a higher Cl / Cd ratio can provide the fan total efficiency as high as 85 – 92 %.

However this efficiency is drastically affected by the factors mentioned earlier such as tip clearance, obstacles to airflow, inlet shapes etc.

Metallic fans are manufactured by adopting either an extrusion or casting process making it difficult to generate ideal aerodynamic profiles. Whereas the FRP blades are normally hand molded which facilitates the generation of optimum aerodynamic profile to meet specific duty conditions more efficiently.

Furthermore, due to the lighter weight, FRP fans need low starting torque resulting in use of lower HP motors. The lightweight of the fans also increases the life of the gearbox, motor and bearing and allows for easy handling and maintenance.

BENEFITS OF PAC Hyperfans

- Optimal aerodynamic design of fan impellers to provide higher efficiency for any specific application.
- Reduction in overall weight of the fan extends the life of the mechanical drive system as well as making it easy to handle and maintain.
- Requires lower drive motor rating and light duty bearing systems.
- Low power consumption results in appreciable energy savings as compared to existing metallic fans.
- FRP Fans produced by composite fabrication processes such as compression molding / resin transfer molding have uniform dimensions and consistent fan blade quality.
- Optimum aerodynamic design of blades results in considerably reduced operational noise levels.
- Improved mechanical strength increases the lifespan of the fan.
- Excellent corrosion and erosion resistance.
- Vibration free operation.
- Special Resin Systems can be incorporated for high temperature, zero static electricity, Phosphate – Fluorine environments and fire retardancy.

IN CONCLUSION:

Optimizing fan performance (considered wider objective of achieving the highest possible overall performance and reliability) is a process that requires close attention to detail, from fan design to choice of an operating point, consideration of the fan's environment, and finally, proper installation. The reward for this close attention will be a long, trouble-free fan life with minimum operating costs.

